

RHINO SERIES TAGS

HT 5050 VDA



VDA compliant square shaped rugged UHF hard tag with global tuning designed specifically for the automotive industry. Optimised to perform on metal, featuring brass inserts that withstand heavy duty riveting. Laser engravable with optional adhesive backing.

PHYSICAL SPECIFICATION

Face Stock

ABS

Tag Sizes

50 x 50 x 11.6 mm (tolerance ± 0.8 mm) | Hole Dia: 5.6mm

Adhesive (optional)

High-performance permanent adhesive with excellent bonding to a variety of substrates

Delivery Format

Single pieces

Weight

34 g

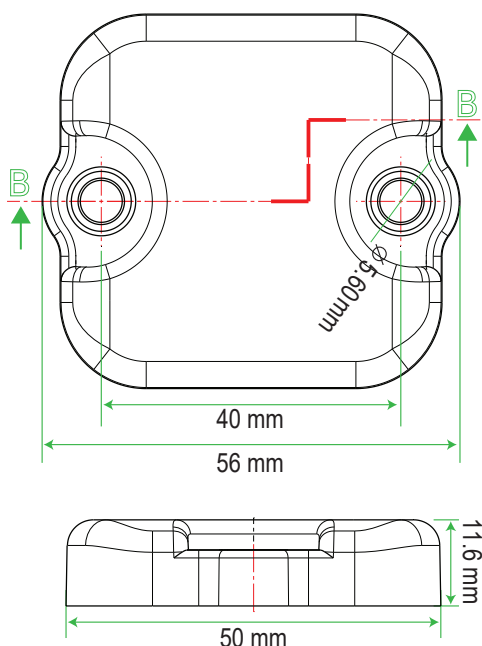

RF SPECIFICATION

Air interface protocol

ISO/IEC 18000-63:2015 and EPCglobal Gen2v2 compliant

Operational frequency

Global 865-928 MHz

IC type*

NXP UCODE 9XM

Memory configuration

EPC 496bit, TID 96bit, USER 752bit

Read range (2W ERP)**

On Metal Up to 13m/ 42.65ft

Applicable Surface Materials

Metallic Surfaces

RADIATION PATTERN

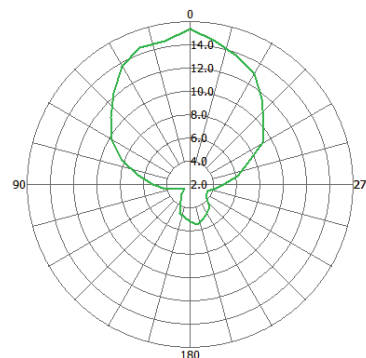

ENVIRONMENTAL RESISTANCE

Operating Temperature

-40°C to +85°C / -58°F to +185°F

Application Temperature

+10°C to +38°C / 50°F to +100.4°F

Vibration Resistance

JESD22-B103B, service condition 2; vibration that is aligned with tag thickness (z-axis)

IP Classification

IP68

Chemical Resistance

No Physical or performance changes in:

- 168 h Saltwater (salinity 10%) exposure
- 168 h Motor oil exposure
- 12 h NaOH (10%) exposure
- 30 min Acetone exposure

Ideal Storage Condition

1 year in +23°C / 73.4°F, 50% RH

Expected Lifetime

Years in normal operating conditions

PERSONALISATION OPTIONS

Pre-encoding

- Customer specific encoding of EPC memory

Customised Laser Engraving

- Customer specific artwork including logo & text, numbers, barcodes etc.

ORDER INFORMATION

Part Number

RF.HT.5050.U9xm

Packaging

100 Per/Box;
4 Inner/Outer

PRODUCT INSTALLATION



- Adhesive: The tag is delivered with an optional adhesive tape attached. While mounting the tag ensure clean and dry surface to achieve maximum bond strength. Ideal application temperature is from +10°C to 38°C / +50°F to +100.4°F and installation beyond this temperature range is not recommended. Bond strength can be improved by applying pressure firmly while mounting the tag.
- Mechanical Fixing: Achieved by using a screw or a pop rivet and is a recommended for environments that involve high mechanical stress. During fixing make sure there is no air gap left in between the metal surface and tag.
- Cable Tie: Metallic or plastic cable ties can also be used to mount the tag onto the surface.

READ RANGE GRAPH

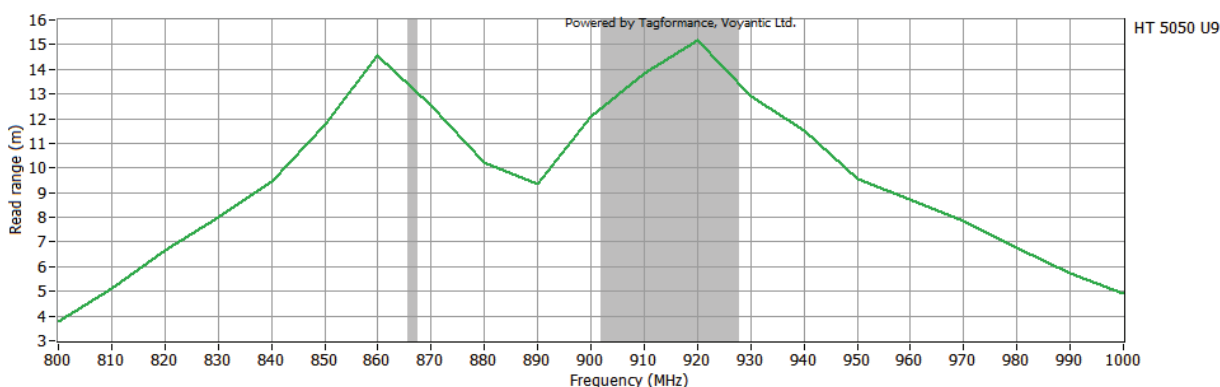

* Other IC's available on request

** The indicated read range values are measured in our laboratory testing environment, where antennas with optimum directivity are used with maximum allowed operating power. Different surface materials and environments may exhibit different results.