



RAIN (UHF) RFID hard tag optimized for securing metal assets. Based on a rugged construction, square footprint and good durability, the tag is made to withstand harsh weather, high impact or other challenging application environments and is ideal for Logistics & Supply chain and manufacturing applications.

### TYPICAL APPLICATIONS

- Supply Chain
- Logistics & Yard management
- Manufacturing

### PHYSICAL SPECIFICATION

Tag Material	ABS
Tag Dimensions	50 x 50 x 10 mm (tolerance $\pm 1$ mm)   Hole Dia: 5.6mm 1.97 x 1.97 x 0.39 inch   Hole Dia: 0.22 in
Adhesive (Optional)	High performance permanent adhesive with excellent bonding to a variety of substrates
Weight	29.5 gms
Delivery Format	Single Pieces

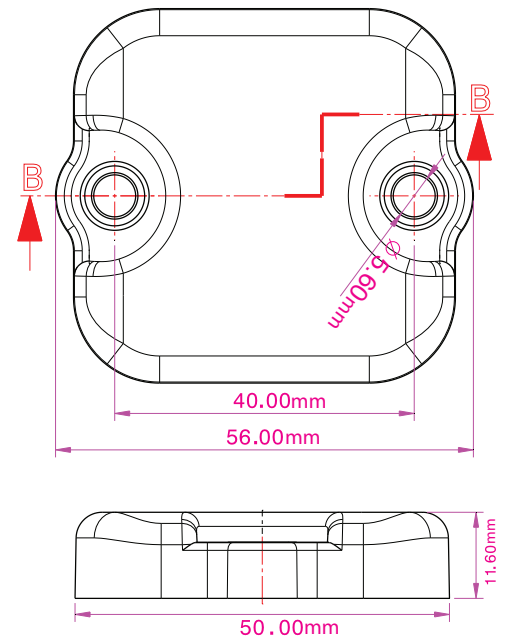

### RF SPECIFICATION

Mode of Operation	Passive
Device Type	Plastic Hard Tag
Air Interface Protocol	EPC Gen2/ISO/IEC 18000 6C
Operational Frequency	Global 860-960 MHz
IC Type*	Alien Higgs 3
Memory Configuration	EPC Size 96 Bits, User Memory 512 Bits, 96 bits TID with 64 bits Unique serial number
Write Cycle Endurance	100,000
Data Retention	Upto 50 years
Applicable Surface Materials	Metallic surfaces
Read Range (In Meters)	ETSI : Upto 10 m FCC : Upto 10 m

# ENVIRONMENTAL RESISTANCE

Operating Temperature	-40°C to +80°C / -40°F to +176°F
Withstands Exposure To	+80°C / +176°F
Peak Temperature	+80°C / +176°F
Adhesive Service Temperature	-40°C to +148°C / -40°F to +298.4°F
Recommended Application Temperature	+10°C to +38°C / 50°F to +100.4°F
Water Resistance (IP Rating)	IP68
Chemical Resistance	No physical or performance changes in: - 168 h Salt water (salinity 10%) exposure - 168 h Motor oil exposure - 12 h NaOH (10%) exposure - 30 min Acetone exposure
Ideal Storage Condition	1 year in +23°C / 73.4°F , 50% RH
Expected Lifetime	Years in normal operating conditions

## PRODUCT INSTALLATION

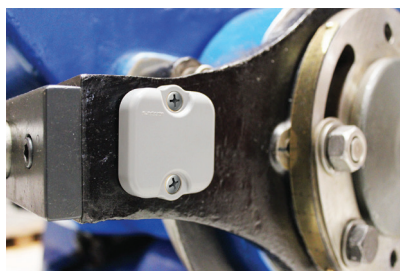

The tag can be attached to the surface using the following fixing methods

- **Adhesive:**  
The tag is delivered with an optional adhesive tape attached. While mounting the tag ensure clean and dry surface to achieve maximum bond strength. Ideal application temperature is from +10°C to 38°C / +50°F to +100.4°F and installation beyond this temperature range is not recommended. Bond strength can be improved by applying pressure firmly while mounting the tag.
- **Mechanical Fixing:**  
Achieved by using a screw or a pop rivet and is a recommended for environments that involve high mechanical stress. During fixing make sure there is no air gap left in between the metal surface and tag.
- **Cable Tie:**  
Metallic or plastic cable ties can also be used to mount the tag onto the surface.

## PERSONALIZATION OPTIONS

### Pre-encoding

- Customer specific encoding of EPC

### Customized Laser Engraving

- Customer specific layout including logo, text, and numbers.

## ORDER INFORMATION

### Part Number

- RF.HT.MOM.5050

### No. of Pieces

- 50 per box.

# RADIATION PATTERN & READ RANGE GRAPH

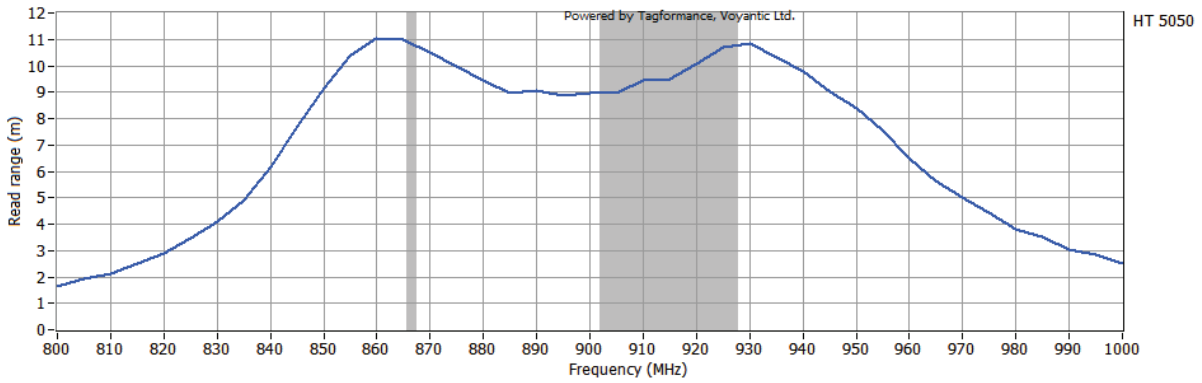
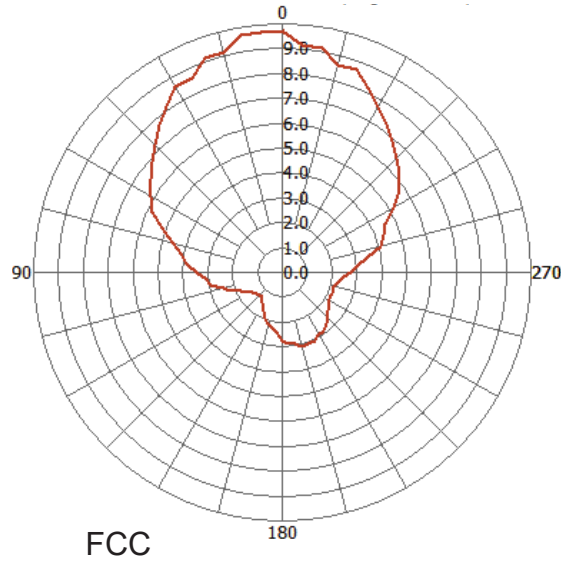
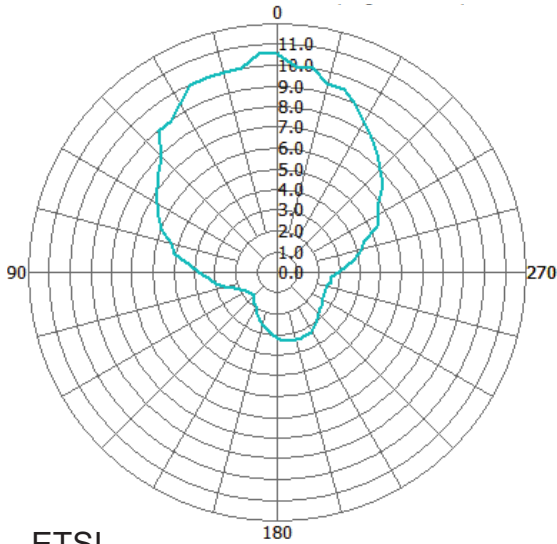

\* Other IC's available on request

\*\* The indicated read range values are measured in our laboratory testing environment, where antennas with optimum directivity are used with maximum allowed operating power. Different surface materials and environments may exhibit different results.



Version : 180221.01